

at 39.3, 37.4, 33.3, 27.7, and 27.7 ppm, respectively. The symmetry of VII dictates the methylene shift assignments. Differentiation of the two methine sets is based on one being deshielded by β -methyl groups.

The spectrum of a carbon tetrachloride solution of III exhibits $(\text{CH}_2)_2$, $(\text{CH}_2)_8$, $(\text{CH})_4$, and $(\text{CH})_4$ signals at 39.4, 31.8, 30.0, and 27.5 ppm, respectively. The shift assignment emulates that of VII except for the expected upfield position of C_1 and C_3 owing to the influence of 1,3-diaxial interactions from the vicinal adamantane unit.

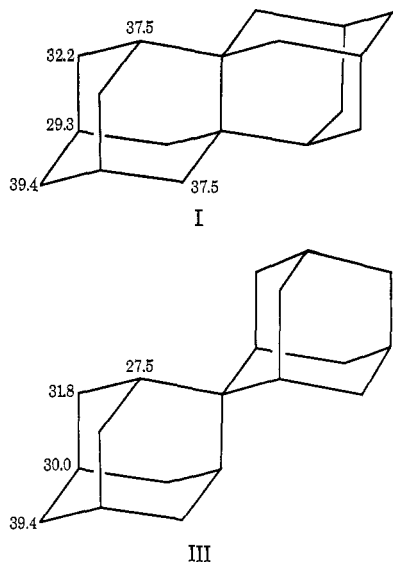

All chemical shifts of I except those of C_7 , C_{14} , C_{15} , and C_{17} are derived from the shifts of III and VII, leaving the signal at 37.5 ppm for the remaining methylenes. The assignment supports strongly the [2]-diadamantane structure I.

The proton nmr spectrum was particularly distinctive. Theory predicts 14 signals, including three AB quartets, from the eight different proton types present. As was observed for III,^{5b} the chemical shift differences of the protons in I are surprisingly large for an unsubstituted, saturated hydrocarbon. All 14 absorptions are clearly resolved in the 220-MHz spectrum of I.

Integration, spin decoupling, and comparison with model compounds allowed assignment of the signals of I to bridgeheads and AB pairs. The pentuplet ($J \sim 3$ Hz) at δ 1.13 (2 H) was due to the bridgehead protons on C_2 and C_9 . A broad singlet at δ 1.99 (4 H, $W_{1/2} \cong 11$ Hz) corresponds to the other group of equivalent bridgehead protons (C_4 , C_6 , C_{11} , and C_{13}). The methylene protons gave rise to three AB quartets (all $J_{AB} \sim 12$ Hz). Being most remote in the molecule, the geminal protons at C_5 and C_{12} are expected to have the smallest chemical shift difference. The doublet pairs at δ 1.63 (2 H) and 1.71 (2 H) were assigned to these protons. Assignment of the other AB systems was made by analogy to the 220-MHz spectrum of 2,2-dimethyladamantane (VII) and [1]diadamantane (III).^{5b} The protons on C_3 (and C_{10} , C_{16} , C_{18}) in I and the C_4 protons in VII and in III have a similar environment. The AB doublets in VII were centered at δ 1.50 and 2.05 ($J_{AB} \sim 12$ Hz) and in III at δ 1.54 and 2.04 ($J_{AB} \sim 12$ Hz). Thus, we assign the doublet pairs at δ 1.49 (4 H) and 2.16 (4 H) in the spectrum of I to the protons on C_3 , C_{10} , C_{16} , and C_{18} . The remaining AB doublet

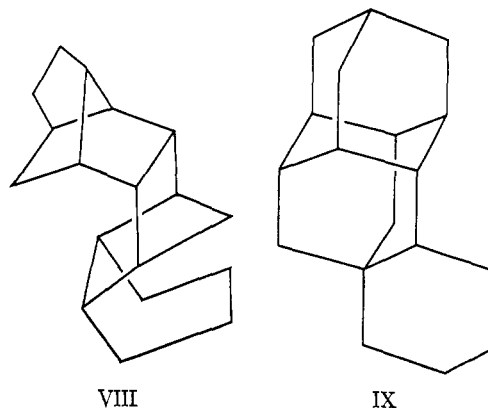

pairs in I at δ 1.03 (4 H) and 2.52 (4 H) were assigned to the C_7 , C_{14} , C_{15} , and C_{17} protons.

We have also attempted to obtain I by isomerization of hexacyclo[11.3.1.1.1.0.2.14.0.3.12.0.5.10]octadecane (VIII), mp 114.9–115.8°, prepared by Diels–Alder addition of butadiene to Katz's dimer,¹⁰ followed by hydrogenation. Under various rearrangement conditions, no [2]diadamantane (I) was detected by glc among the several products. The major component ($\sim 70\%$), collected by preparative glc, was shown by its mass spectrum ($\text{P}^+ m/e$ 242 = $\text{C}_{18}\text{H}_{26}$) to be an isomerization and not a disproportionation product. Structure IX, the most stable cyclohexanodiamantane, appeared to be an attractive possibility for the major component as molecular mechanics calculations¹¹ actually predict IX (ΔH_f° calcd = -50.4 kcal/mol) to be appreciably more stable than I (ΔH_f° calcd = -42.6 kcal/mol). However, the ^{13}C nmr spectrum excluded IX from consideration, and the correct structure has not yet been established. This experiment demonstrates again that synthesis of higher diamondoid molecules by isomerization can be dependent on the choice of starting material.

We have already prepared [2]diadamantane (I) in large quantity and are exploring its chemistry.

Acknowledgments. This research was supported at Princeton by grants from the National Institutes of Health (GM-19134), the National Science Foundation, and Hoffmann La Roche, Inc., Nutley, N. J.

(10) J. J. Mrowca and T. J. Katz, *J. Amer. Chem. Soc.*, **88**, 4012 (1966).

(11) Performed by E. Engler using a force field essentially that described by J. L. Fry, E. M. Engler, and P. v. R. Schleyer, *J. Amer. Chem. Soc.*, **94**, 4628 (1972).

W. David Graham, Paul von R. Schleyer*
Department of Chemistry, Princeton University
Princeton, New Jersey 08540

Edward W. Hagaman, Ernest Wenkert
Department of Chemistry, Indiana University
Bloomington, Indiana 47401

Received April 9, 1973

Reaction of Alkenylboronic Acids with Iodine under the Influence of Base. A Simple Procedure for the Stereospecific Conversion of Terminal Alkynes into *trans*-1-Alkenyl Iodides via Hydroboration

Sir:

trans-1-Alkenylboronic acids, readily prepared *via* the hydroboration of 1-alkynes with catecholborane fol-

lowed by hydrolysis,¹ undergo a rapid reaction with iodine under the influence of sodium hydroxide at 0° in ethereal solvents to give *trans*-1-alkenyl iodides in quantitative yield. The stereochemical purity of the product is >99%. Consequently, this development provides a very simple stereospecific route from the terminal alkynes to the corresponding *trans*-1-alkenyl iodides.

Reaction of iodine with trialkylboranes and dialkylborinic acids under the influence of base yields the alkyl iodides.² On the other hand, the trialkenylboranes and dialkenylborinic acids react with iodine in the presence of base to produce the corresponding *cis*,*trans*-dienes.^{3,4} It appeared possible to circumvent this particular reaction by treating the simple alkenylboronic acid with iodine in the presence of base. Accordingly, a solution of *trans*-1-octenylboronic acid in ether was mixed with 3 equiv of aqueous sodium hydroxide and treated with an ether solution of 1 equiv of elemental iodine at 0°. The iodine color disappeared almost as fast as it was added, with the iodine color completely vanishing within 15 min after the addition was completed. Gas chromatographic (gc) analysis of the organic layer revealed the quantitative formation of the 1-octenyl iodide. Spectroscopic examination (ir and pmr) of the isolated product revealed it to be pure *trans*-1-octenyl iodide. The reaction was extended to other representative *trans*-1-alkenylboronic acids, such as *trans*-1-hexenylboronic acid, *trans*-2-cyclohexylethenylboronic acid, and *trans*-2-phenylethenylboronic acid. All underwent the reaction rapidly, in the same manner (eq 1).

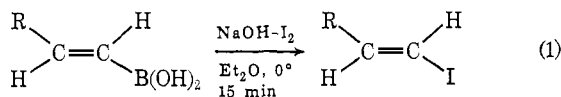

Terminal acetylenes readily react with catecholborane to give the catechol ester of the corresponding *trans*-1-alkenylboronic acid¹ (eq 2). Unfortunately,

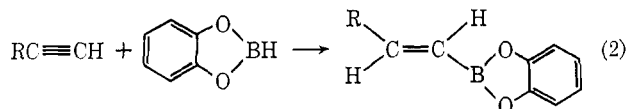

catechol interferes with the base-induced reaction of iodine with the *trans*-1-alkenylboronic acid. However, a simple treatment of the ester with water produces the *trans*-1-alkenylboronic acid sufficiently free of catechol to be utilized directly for the reaction with iodine (eq 1). Consequently, *trans*-1-alkenyl iodides can now be synthesized readily from the corresponding terminal alkynes by (1) hydroboration with catecholborane, (2) hydrolysis of the ester, and (3) treatment of the boronic acid with iodine in the presence of sodium hydroxide. Typical results are summarized in Table I.

The following procedure for the synthesis of *trans*-1-octenyl iodide is representative. 1-Octyne (50 mmol) and catecholborane (50 mmol) were stirred in a 100-ml flask for 2 hr under nitrogen at 70° to form the catechol

(1) H. C. Brown and S. K. Gupta, *J. Amer. Chem. Soc.*, **94**, 4370 (1972).

(2) H. C. Brown, M. W. Rathke, and M. M. Rogić, *ibid.*, **90**, 5038 (1968).

(3) G. Zweifel, N. L. Polston, and C. C. Whitney, *ibid.*, **90**, 6243 (1968).

(4) H. C. Brown and N. Ravindran, *J. Org. Chem.*, **38**, 1617 (1973).

Table I. Stereospecific Conversion of 1-Alkynes into *trans*-1-Alkenyl Iodides via Hydroboration-Hydrolysis-Iodination

Alkyne	Yield of <i>trans</i> -1-alkenylboronic acid, % ^a	Yield of <i>trans</i> -1-alkenyl iodide, % ^b
1-Hexyne	90	99, ^c 89 ^d
1-Octyne	90	100, ^c 90 ^d (80, ^c 71 ^d)
Cyclohexylethyne	93	100, ^c 93 ^d
Phenylethyne	(85)	93, ^c 79 ^d

^a See ref 1. ^b The iodides were identified and characterized by means of gc, ir, pmr, and mass spectrometry. The *cis* isomer, if any was present, was below the limit of detection. The stereochemical purity of the product is >99% *trans*. ^c Based on boronic acid. ^d Based on alkyne. The yields by isolation are given in parentheses.

ester of 1-octenylboronic acid.¹ The mixture was cooled to room temperature and stirred with 50 ml of water for 2 hr at 25°, to effect the hydrolysis of the ester.¹ The resulting mixture was cooled to 0° and the white solid, *trans*-1-octenylboronic acid, was collected by filtration and washed free of the catechol using ice-cold water.⁵ The boronic acid was then dissolved in 50 ml of ether in a 500-ml flask and cooled to 0°. Aqueous sodium hydroxide (50 ml, 3 *N*) was then added followed by 60 mmol of elemental iodine (20% excess) in about 150 ml of ether, while stirring at 0°. The mixture was stirred for 30 min at 0°. The excess iodine was then destroyed with aqueous sodium thiosulfate solution. The ether solution of *trans*-1-octenyl iodide was separated, washed with water, and dried over anhydrous magnesium sulfate. After removing the solvent, the pure *trans*-1-octenyl iodide was obtained in 71% yield by distillation at 58° (0.2 mm). The product was characterized by ir (945 cm⁻¹), pmr [δ 6.5 (1 H, m), 5.96 (1 H, d, *J* = 15 Hz), 0.5–2.5 (13 H, m)], and mass spectrometry [*m/e* 238 (100), 167 (42), 154 (53)].

The corresponding reaction of internal alkenylboronic acid with iodine and base takes another course. We are currently exploring this reaction.

Although we have not yet made a specific study of the mechanism of this synthesis of *trans*-1-alkenyl iodides, it is evident that the reaction possesses highly interesting characteristics. First, iodine fails to react at any significant rate with the free acid. However, in the presence of base the reaction with iodine is practically instantaneous.⁶ Presumably, the base neutralizes the boronic acid and it is this species (1) (eq 3) which reacts with the iodine.

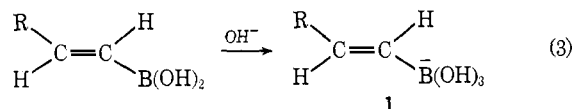

The production of vinyl iodide is significantly slower than the uptake of iodine. Thus, the addition of 1.2 mmol of iodine in ether to a vigorously stirred solution containing 3.0 mmol of *trans*-1-octenylboronic acid and 9.0 mmol of sodium hydroxide led to an essentially

(5) The filtration and the subsequent operations were done open to the atmosphere.

(6) Ethereal iodine reacts with sodium hydroxide fairly rapidly under the experimental conditions. However, in the presence of vinylboronic acid the reaction of iodine with the base must be negligible since there is realized a quantitative formation of the vinyl iodide with the use of the stoichiometric amount of iodine.

instantaneous disappearance of the iodine. However, analysis of the ether layer revealed the presence of 0.44 mmol of iodide in 1 min, 1.02 mmol in 5 min, and 1.21 mmol in 15 min.

This result appears to rule out a mechanism involving a direct reaction of iodine with the vinyl-boron bond.⁷ It suggests that the fast reaction of the neutralized vinylboronic acid and iodine results in an intermediate which is converted into the vinyl iodide relatively slowly. Further study is necessary to elaborate the nature of this intermediate.

It was previously reported that the stereospecific *trans*-1-alkenylmercuric acetates can be prepared from 1-alkynes *via* hydroboration with catecholborane.⁸ In the present study the stereospecific *trans*-1-alkenyl iodides can likewise be prepared from these intermediates. Consequently, these alkenylboronic acids may provide valuable new intermediates leading to a variety of derivatives.

Irrespective of future developments, the present procedure provides a very simple, essentially quantitative synthesis of *trans*-1-alkenyl iodides. The alternative method for the synthesis of these compounds is the hydroalumination procedure of Zweifel and Whitney.⁹ The *trans*-1-alkenyl iodides are finding important applications in the synthesis of prostaglandins.^{10,11}

(7) We also observed that phenylboronic acid is not converted into phenyl iodide under the same conditions.

(8) R. C. Larock, S. K. Gupta, and H. C. Brown, *J. Amer. Chem. Soc.*, **94**, 4371 (1972).

(9) G. Zweifel and C. C. Whitney, *ibid.*, **89**, 2753 (1967).

(10) A. F. Kluge, K. G. Untch, and J. H. Fried, *ibid.*, **94**, 7827 (1972).

(11) C. J. Sih, P. Price, R. Sood, R. G. Salomon, G. Peruzzotti, and M. Casey, *ibid.*, **94**, 3643 (1972); C. J. Sih, J. B. Heather, G. P. Peruzzotti, P. Price, R. Sood, and L. F. H. Lee, *ibid.*, **95**, 1676 (1973).

(12) Visiting scholar on funds provided by the Fuji Photo Film Co., Ltd., Tokyo, Japan.

(13) Postdoctoral research associate on grants provided by G. D. Searle and Co., Chicago, Ill., and the National Science Foundation (27742X).

Herbert C. Brown,* Tsutomu Hamaoka,¹² N. Ravindran¹³

Richard B. Wetherill Laboratory, Purdue University
West Lafayette, Indiana 47907

Received April 24, 1973

Biosynthesis of the 5-Fluoropolyoxins, Aberrant Nucleoside Antibiotics

Sir:

The polyoxins represent a new group of pyrimidine nucleoside peptide antibiotics which are elaborated by *Streptomyces cacaoi*.¹ They are extremely toxic toward phytopathogenic fungi, but do not inhibit bacteria, plants, or animals.^{2,3} It is the structural similarity of the polyoxins with UDP-*N*-acetylglucosamine that makes these compounds inhibitors for chitin synthesis. Because the pyrimidine chromophore in ten of the polyoxins has either the 5-methyl, 5-hydroxymethyl, or 5-carboxy substituent, it was of interest to study the biosynthesis of these 5-substituted uracils. There is a new enzyme system in *S. cacaoi* that synthesizes the thymine (T) and/or hydroxymethyluracil (HMU)

(1) K. Isono, K. Asahi, and S. Suzuki, *J. Amer. Chem. Soc.*, **91**, 7490 (1969).

(2) K. Isono, J. Nagatsu, Y. Kawashima, and S. Suzuki, *Agr. Biol. Chem.*, **29**, 848 (1965).

(3) K. Isono, J. Nagatsu, K. Kobinata, K. Sasaki, and S. Suzuki, *Agr. Biol. Chem.*, **31**, 190 (1967).

chromophore from uracil (U) and C-3 of serine without proceeding through thymidylate synthetase (to be published elsewhere). Because uracil was an efficient precursor of pyrimidine chromophore, we became interested in the possibility of biosynthesizing unnatural polyoxin by using uracil analogs in place of U. First, these experiments would define the specificity of the enzyme system that catalyzes the biosynthesis of the polyoxins. Second, the formation of an "aberrant nucleoside antibiotic" would be extremely useful in the preparation of a polyoxin with broader inhibitory properties. We have now been able to show that 5-fluorouracil (FU) is very efficiently incorporated and forms 5-fluoropolyoxin L (1) and 5-fluoropolyoxin M (2), which have broad activity to bacteria (see Chart I).

Chart I

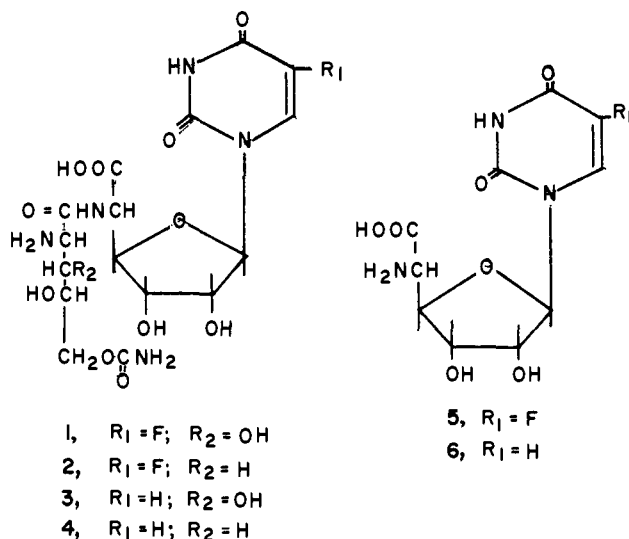

S. cacaoi var *asoensis*¹ was fermented with an organic medium in shaking flasks.³ At the stationary phase, FU was added (10^{-2} M). Three days later, polyoxin complex was isolated.³ Each polyoxin was separated on a cellulose column. The main components were 1, 2, polyoxin L¹ (3), and polyoxin M (4).⁴ FU was incorporated into polyoxins without any dilution of radioactivity. The base ratio of the polyoxin complex (FU:U:T:HMU \approx 0.6:1:0.1:0.1) is markedly different from the normal ratio (U:T:HMU \approx 1:2:3). Apparently, the fluoropolyoxins formed in the cell inhibit T and HMU chromophore formation.

5-Fluoropolyoxin L (1) was obtained as a white powder: C₁₆H₂₂N₅O₁₂F; $[\alpha]^{25D} +45.1^\circ$ (c 1, H₂O); pK_a (3.1) 6.65, 7.85; u_{vmax} (H₂O) 0.05 N HCl, 267 (ϵ 8100); 0.05 N NaOH, 268 (ϵ 6400); pmr (D₂O) δ 5.86 (br d, 1, H-1'), 7.91 (d, 1, H-6). Alkaline hydrolysis² gave FU, 5-fluorouracilpolyoxin C (5), 2-amino-2-deoxy-L-xylonic acid (7),¹ CO₂, and NH₃.

5-Fluoropolyoxin M (2) was obtained as a white powder: C₁₆H₂₂N₅O₁₁F; $[\alpha]^{25D} +42.5^\circ$ (c 1, H₂O); pK_a (2.6), 7.05, 8.05; u_{vmax} (H₂O) 0.05 N HCl, 267 (ϵ 7900); 0.05 N NaOH, 268 (ϵ 6400); pmr (D₂O) δ 5.84 (br d, 1, H-1), 7.84 (d, 1, H-6), 2.08 (m, 2'', 3''-CH₂). Alkaline hydrolysis gave FU, 5, 2-amino-2,3-dideoxy-L-xylonic acid (8),¹ CO₂, and NH₃.

Compound 5 was crystallized with mp 225–226°

(4) K. Isono, S. Suzuki, M. Tanaka, T. Nanbata, and K. Shibuya, *Tetrahedron Lett.*, 425 (1970).